

MULTIPACK - MP 21 COMBINATION PACKAGING

ASSEMBLY DETAILS:

FIBREBOARD

BOX: 4GV

OUTER PACKAGING

CODE:840

GB/5840

FOR GROUPS: I II III
X Y Z



4GV/X21/S/**

UP TO A
GROSS PACKAGE
WEIGHT OF:

21K

MAXIMUM
PERMITTED
WEIGHT OF
CONTENTS:

14K

(Product & Containers)

External Dimensions:

435 x 285 x 570mm

Internal Dimensions:

425 x 275 x 555mm

NOTES:

SEE Special **PACKAGING DETAILS** and other information overleaf.

Vermiculite IS Required as absorbent filling of remaining available space.

Once the box is closed, seal in 'U' tape fashion with 75mm adhesive tape.

** Denotes year of manufacture

Adhesive tape, labels and vermiculite can be purchased separately from Air Sea Containers

EXAMPLES OF INNER CONTAINERS

EXCLUDING:
Explosives and Radioactives

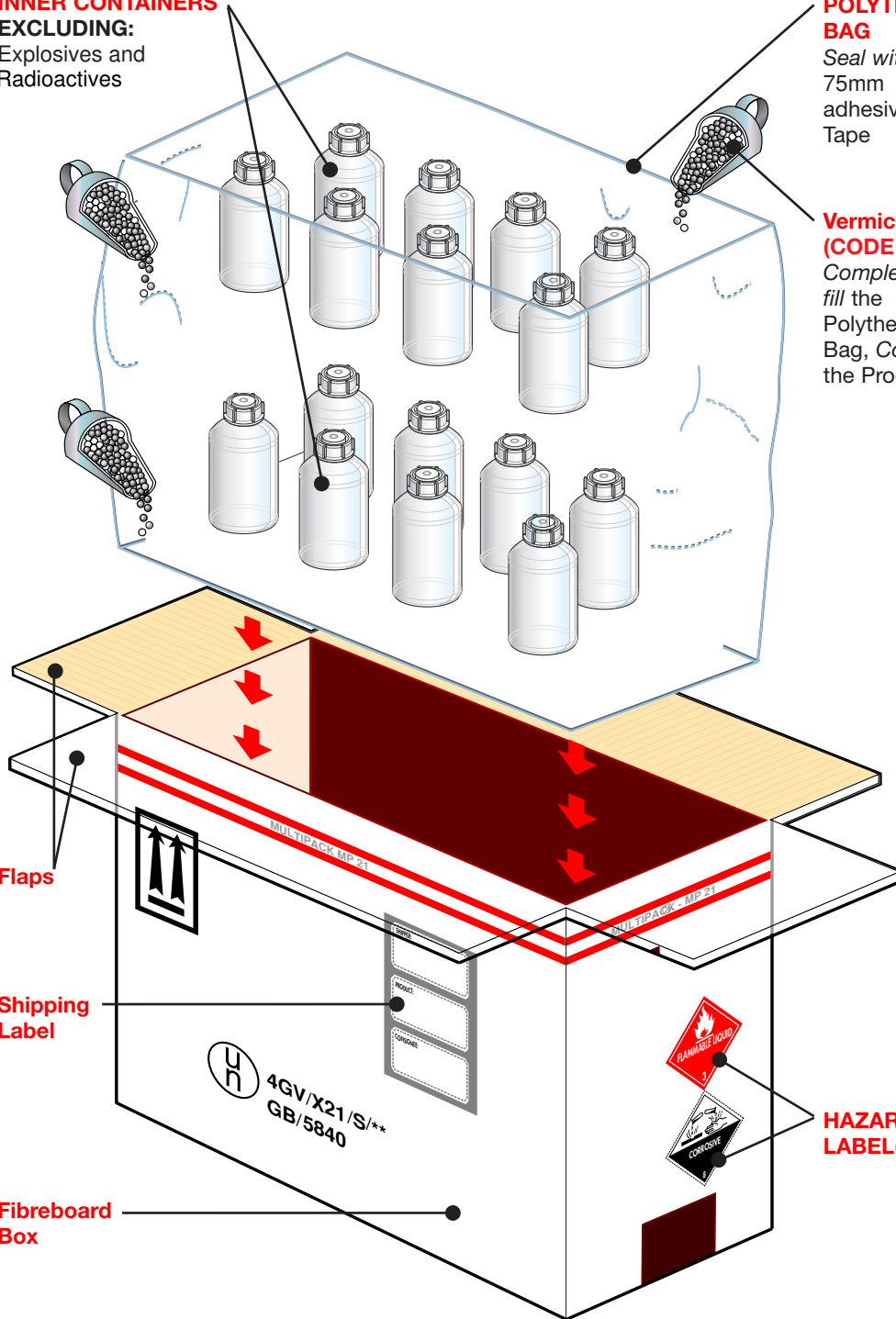

POLYTHENE BAG
Seal with 75mm adhesive Tape

Vermiculite (CODE 38)
Completely fill the Polythene Bag, Covering the Product.

Flaps

Shipping Label

Fibreboard Box

HAZARD LABEL(S)

INDICATION OF PROPORTION

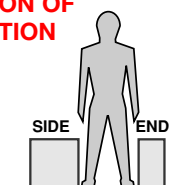

An evenly distributed layer of Vermiculite must cover the bottom and top of the packing spaces.

Continued Overleaf..



AIR SEA CONTAINERS LTD.

521 Cavendish Street
Birkenhead, CH41 8FZ
Great Britain

Tel: +44 (0) 151 653 1500

Fax: +44 (0) 151 653 1515

Web site: www.airseadg.com

E-mail: uk@airseadg.com

MULTIPACK - MP 21 COMBINATION PACKAGING

ASSEMBLY DETAILS:

FIBREBOARD BOX: 4GV OUTER PACKAGING

CODE:840

INSTRUCTIONS FOR USE:

Refer to the illustrations on this page and overleaf.

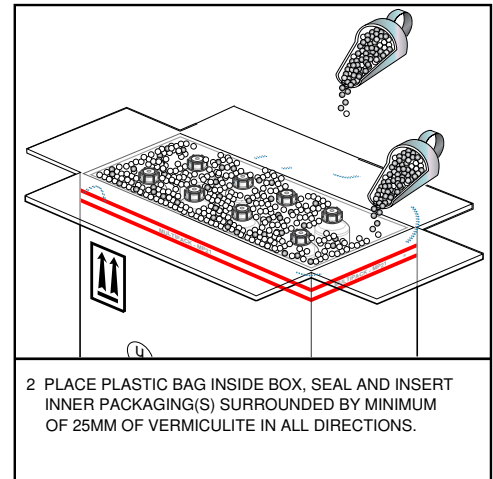
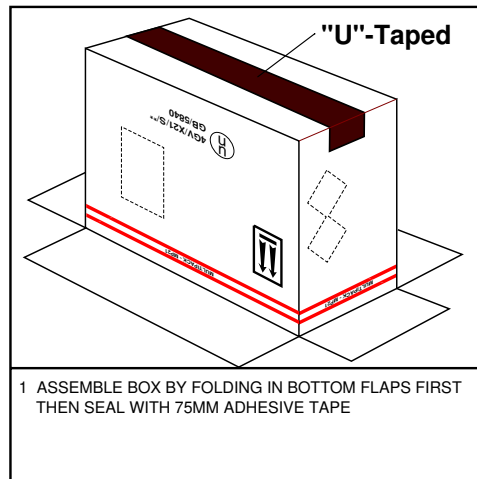

1 ASSEMBLE BOX BY FOLDING IN BOTTOM FLAPS FIRST THEN SEAL WITH 75MM ADHESIVE TAPE IN 'U' SHAPE FASHION.

2 PLACE PLASTIC BAG INSIDE BOX, SEAL AND INSERT INNER PACKAGING SURROUNDED BY MINIMUM OF 25MM OF VERMICULITE IN ALL DIRECTIONS.

3 COMPLETELY FILL ALL REMAINING SPACE IN THE BAG WITH VERMICULITE, SEAL BAG WITH 75MM ADHESIVE TAPE.

4 CLOSE TOP FLAPS OF BOX AND SEAL WITH 75MM ADHESIVE TAPE IN 'U' SHAPE FASHION.

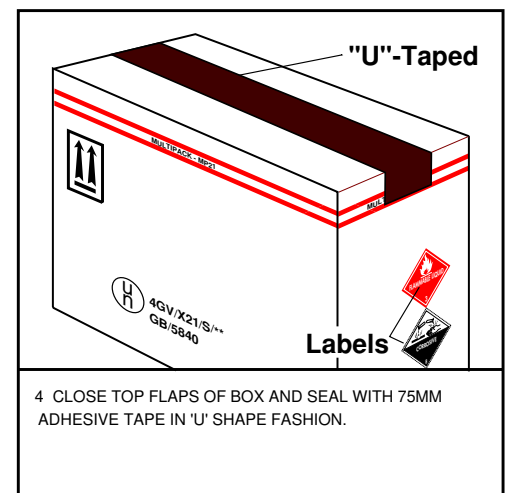
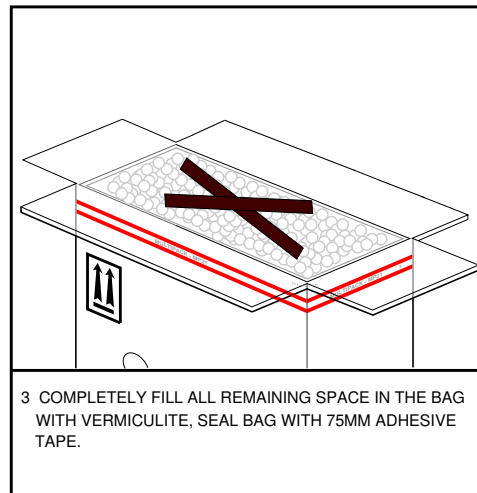

IT IS THE SHIPPERS RESPONSIBILITY TO ENSURE ALL APPROPRIATE REGULATIONS GOVERNING THE TRANSPORTATION OF DANGEROUS GOODS ARE STRICTLY FOLLOWED.

Our MULTIPACK, is a special 4GV OUTER PACKAGING approved under U.N. Test criteria which allows transport of *NON-SPECIFIED INNER CONTAINERS and their contents up to a stated maximum weight.*

In MULTIPACK - MP 21 the maximum permitted weight of the INNER CONTAINERS AND THEIR PRODUCT CONTENTS *must not exceed 14 KILOGRAMS*, whilst the GROSS PACKAGE WEIGHT *must not exceed 21 KILOGRAMS*.

MULTIPACK - MP 21 *must be assembled and packed strictly as instructed* and is then approved for the transportation of Packing Groups I, II, III, (X, Y, Z) Dangerous Goods.

CLASS 1 EXPLOSIVES OR CLASS 7 RADIOACTIVES MUST NOT BE PACKED IN THIS BOX.



AIR SEA CONTAINERS LTD.

521 Cavendish Street
Birkenhead, CH41 8FZ
Great Britain

Tel: +44 (0) 151 653 1500

Fax: +44 (0) 151 653 1515

Web site: www.airseadg.com

E-mail: uk@airseadg.com